

# Model GP7124A

---

Triplex Ceramic  
Plunger Pump  
Operating Instructions/  
Repair and Service  
Manual

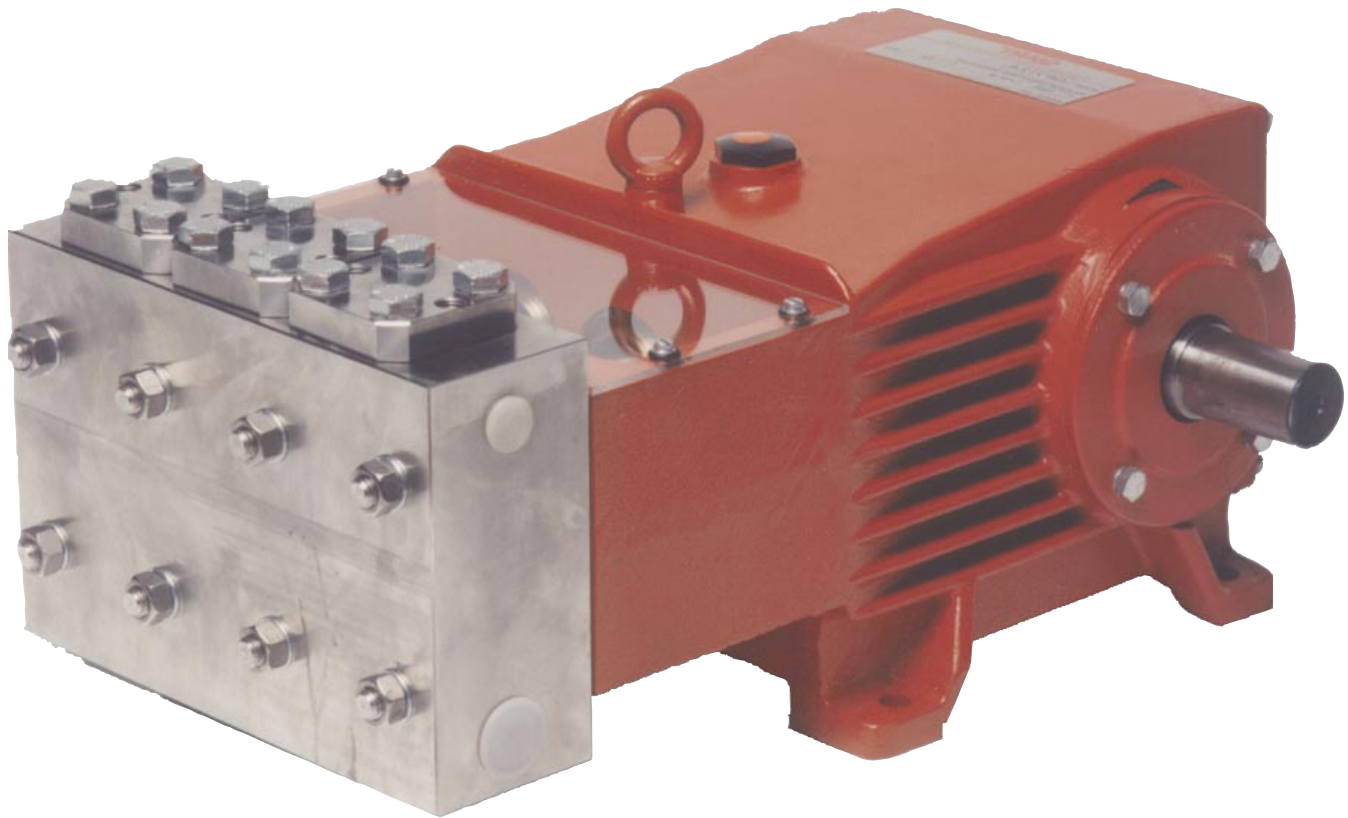

## Contents:

Installation Instructions:	page 2
Pump Specifications:	page 3
Parts List/Exploded View:	pages 4-5
Repair & Service:	pages 6-7
Torque Specifications:	page 7
Dimensions:	back page
Warranty Information:	back page

---

## INSTALLATION INSTRUCTIONS

---

Installation of the Giant Industries, Inc., pump is not a complicated procedure, but there are some basic steps common to all pumps. The following information is to be considered as a general outline for installation. If you have unique requirements, please contact Giant Industries, Inc. or your local distributor for assistance.

1. The pump should be installed flat on a base to a maximum of a 15 degree angle of inclination to ensure optimum lubrication.
2. The inlet to the pump should be sized for the flow rate of the pump with no unnecessary restrictions that can cause cavitation. Teflon tape should be used to seal all joints. If pumps are to be operated at temperatures in excess of 140 F, it is important to insure a positive head to the pump to prevent cavitation.
3. The discharge plumbing from the pump should be properly sized to the flow rate to prevent line pressure loss to the work area. It is essential to provide a safety bypass valve between the pump and the work area to protect the pump from pressure spikes in the event of a blockage or the use of a shut-off gun.
4. Use of a dampener is necessary to minimize pulsation at drive elements, plumbing, connections, and other system areas. The use of a dampener

with Giant Industries, Inc. pumps is optional, although recommended by Giant Industries, Inc. to further reduce system pulsation. Dampeners can also reduce the severity of pressure spikes that occur in systems using a shut-off gun. A dampener must be positioned downstream from the unloader.

5. Crankshaft rotation on Giant Industries, Inc. pumps should be made in the direction designated by the arrows on the pump crankcase. Reverse rotation may be safely achieved by following a few guidelines available upon request from Giant Industries, Inc. Required horsepower for system operation can be obtained from the chart on page 3.
6. Before beginning operation of your pumping system, remember: Check that the crankcase and seal areas have been properly lubricated per recommended schedules. Do not run the pump dry for extended periods of time. Cavitation will result in severe damage. Always remember to check that all plumbing valves are open and that pumped media can flow freely to the inlet of the pump.

Finally, remember that high pressure operation in a pump system has many advantages. But, if it is used carelessly and without regard to its potential hazard, it can cause serious injury.

---

### IMPORTANT OPERATING CONDITIONS

Failure to comply with any of these conditions invalidates the warranty

1. Prior to initial operation, add oil to crankcase so that the oil level is between the two lines on the oil dipstick. DO NOT OVERFILL. **SAE 80 Industrial Gear oil may be used.** Crankcase oil should be changed after the first 50 hours of operation, then at regular intervals of 500 hours or less depending on operating conditions.

2. Pump operation must not exceed rated pressure, volume, or RPM. A pressure relief device must be installed in the discharge of the system.
3. Acids, alkalines, or abrasive fluids cannot be pumped unless approval in writing is obtained before operation from Giant Industries, Inc.
4. Run the pump dry approximately 10 seconds to drain the water before exposure to freezing temperatures.

# Specifications Model GP7124A

Volume .....	Up to 12.7 GPM
Discharge Pressure .....	Up to 10000 PSI <sup>1</sup>
Speed .....	Up to 750 RPM
Inlet Pressure .....	Up to 90 PSI <sup>2</sup>
Plunger Diameter .....	24mm
Plunger Stroke .....	48mm
Crankshaft Diameter .....	48mm
Key Width .....	14mm
Crankshaft Mounting .....	Either side
Shaft Rotation .....	Top of pulley towards manifold
Temperature of Pumped Fluids .....	Up to 140 °F
Inlet Ports .....	(2) 1 1/4" NPT
Discharge Ports .....	(2) 3/4" NPT
Weight .....	374 lbs.
Crankcase Oil Capacity .....	1.6 Gal.
Fluid End Material .....	Stainless Steel
Volumetric Efficiency @ 700 RPM .....	89%
Mechanical Efficiency @ 700 RPM .....	83%

Consult the factory for special requirements that must be met if the pump is to operate beyond one or more of the limits specified above.

**NOTES:** <sup>1</sup>Intermittent Duty 10.1 GPM @ 10,000 PSI. System Requirements:  
No Unloader or Regulator allowed. Must use a safety valve and dump gun.

<sup>2</sup>Positive inlet pressures are recommended!

<b>GP7124A HORSEPOWER REQUIREMENTS</b>					
RPM	GPM	3000 PSI	5000 PSI	6000 PSI	7250 PSI
300	5.1	10.9	18.1	21.7	26.3
400	6.8	14.5	24.2	29.0	35.0
550	9.3	19.9	33.2	39.9	48.2
600	10.1	21.7	36.2	43.5	52.5
650	11.0	23.6	39.3	47.1	56.9
700	11.8	25.4	42.3	50.7	61.3
750	12.7	27.2	45.3	54.3	65.7

RPM	GPM	10000 PSI*
600	10.1	71.4

**\*FOR INTERMITTENT DUTY ONLY!**

**MUST RUN PUMP WITH A DUMP GUN AND SAFETY VALVE!  
AN UNLOADER AND REGULATOR MUST NOT BE USED!**

**HORSEPOWER RATINGS:**

The rating shown are the power requirements for the pump. Gas engine power outputs must be approximately twice the pump power requirements shown above.

We recommend a 1.1 service factor be specified when selecting an electric motor as the power source.

To compute specific pump horsepower requirements, use the following formula:

$$\frac{\text{GPM} \times \text{PSI}}{1400} = \text{hp}$$

## GP7124A PARTS LIST

<u>ITEM</u>	<u>PART</u>	<u>DESCRIPTION</u>	<u>QTY.</u>	<u>ITEM</u>	<u>PART</u>	<u>DESCRIPTION</u>	<u>QTY.</u>
1	07600	Crankcase	1	34	13137	Flinger	3
2	13000	Oil Filler Plug Assembly	1	36	13138	Plunger	3
4	07601	Crankcase Cover	1	38	13408	Stuffing Box	3
5	07602	Hexagon Screw	1	39	13409	Seal Case	3
8	07603	Oil Dip Stick	1	39A	07150	O-Ring	6
9	01009	O-Ring, Dip Stick	1	39B	07683	Support Ring	6
10	13133	Hexagon Screw	12	40	13400	Grooved Seal	3
11	13134	Spring Washer	12	41	07718	Support Ring	3
12	07109	Drain Plug	2	42	07685	Packing	3
13	07182	Gasket, Drain Plug	2	43	13410	Teflon Support Ring	3
14	07607	Bearing Cover	2	44	13238	Circlip	3
15	07608	Radial Shaft Seal	2	49	13159	Stud Bolt	8
16	07184	O-Ring	2	49A	13160	Nut	8
20	07610	Taper Roller Bearing	2	50	13411	Valve Casing	1
20A	07611	Fitting Disc (Shim)	1	50A	13162	Cylinder Stud	2
21	07612	Shaft Protector	1	51	13146	Inlet Valve Assy.	3
22	13405	Crankshaft	1	51A	07693	Support Ring	6
23	07614	Key	1	51B	12055	O-Ring	6
24	13182	Connecting Rod Assy.	3	51C	13131	Inlet Valve Seat	3
24A	13406	Fitting Screw	6	51D	13130	Valve Plate	6
24B	13407	Washer	6	51E	07062	Valve Spring	6
25	13183	Crosshead Assy.	3	51F	13147	Spacer Pipe	6
28	13184	Crosshead Pin	3	52	13148	Discharge Valve Assy.	3
30	07619	Cover Plate	1	52C	13149	Discharge Valve Seat	3
30A	07225	Hexagon Screw	8	58	07699	Plug	3
30B	13136	Grommet	4	58A	07700	O-Ring	3
30C	07622	Washer	8	58B	07701	Support Ring	3
30D	13154	Cover	1	58C	07702	Hexagon Screw	12
31	07623	Eye Bolt	1	59	07703	Plug	3
32	07624	Radial Shaft Seal	3	59A	07704	Seal	3
32A	07625	Shaft Seal	3	60	12253	Plug G 3/4	1
33	07626	Seal Retainer	3	61	12251	Plug G 1-1/4	1
33A	07627	O-Ring	3	66	13362	Disc for Crankshaft	1
33B	07628	Circlip	3	67	13358	Hexagon Screw	1

# Exploded View - GP7124A

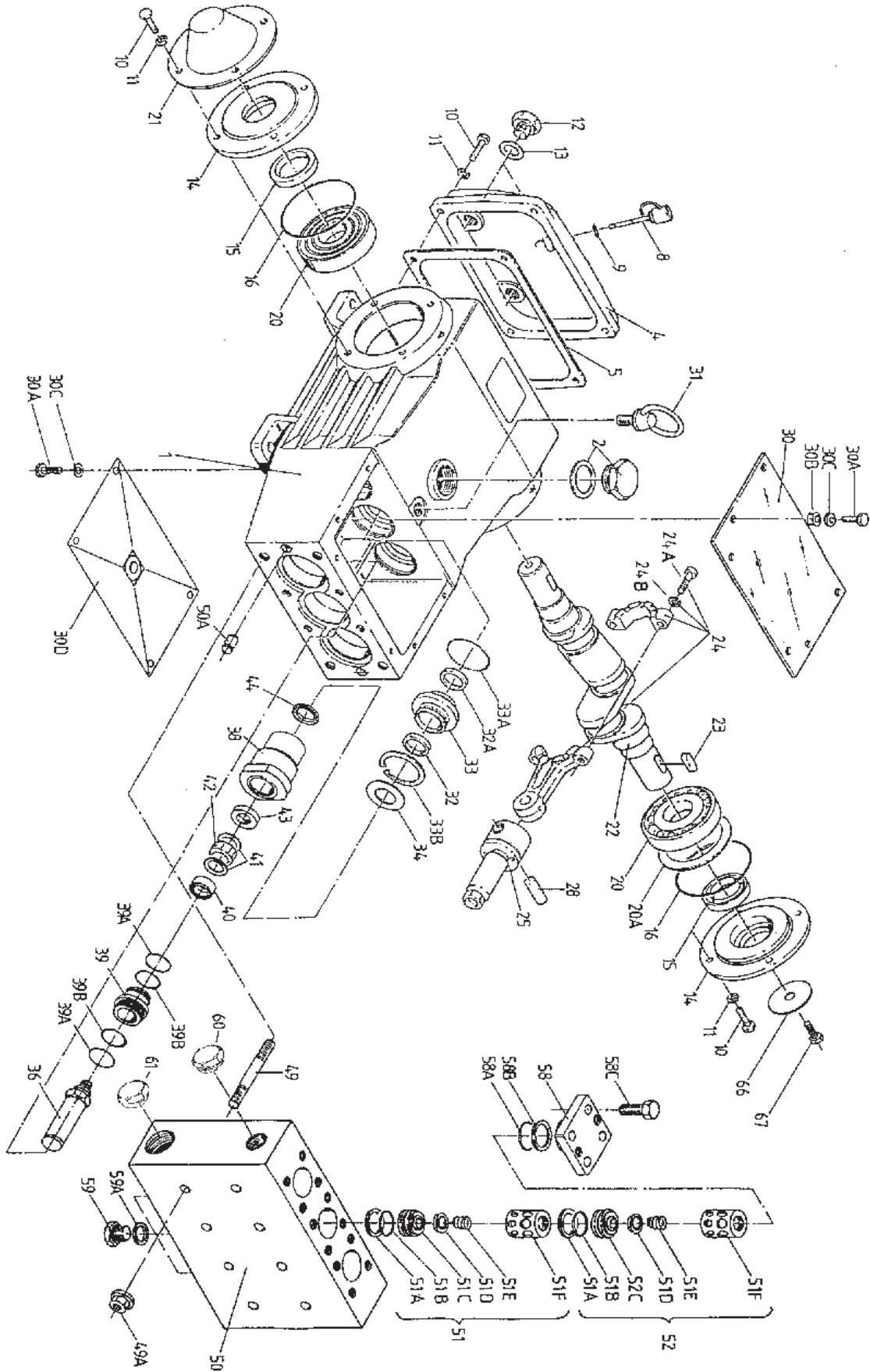

---

## GP7124A REPAIR INSTRUCTIONS

---

**NOTE:** Always take time to lubricate all metal and non-metal parts with a light film of oil before reassembling. This step will help ensure proper fit, at the same time protecting the pump non-metal parts (elastomers) from cutting and scoring.

### TO CHECK VALVES

Loosen screws (58C), take plugs (58) out of valve casing with two screws. Take out complete valve (51) using either tool (part #07662) or stud bolt. Valve seats (51C and 52C) are pressed out of spacer pipe (51F) by hitting the valve plate (51D) with a bolt. Check surfaces of valve plate, valve seat, O-rings (51B, 58A) and replace worn parts.

**CAUTION:** When reassembling: The suction valve seat (51C) is 1mm smaller in diameter than the discharge valve seat (52C). Suction valve seats are marked "S" and always have to be installed first. Discharge valve seats are marked "P" and are always to be installed on top of suction valve. Plugs (58) are to be tensioned down evenly with screws (58C) and crosswise at 210NM.

### TO CHECK SEALS AND PLUNGER PIPE

Loosen nuts (49A) and remove pump head. Separate plunger (36) from crosshead (25) by means of two open-end wrenches (size 22 and 27). Pull seal sleeves (38) out of their fittings in the crankcase. Take seal case (39) out of seal sleeve (38). Take seal-pack (40-43) out of seal sleeve. After removing the circlip ring (44) take seal-pack (43A-C) out of seal sleeve (38).

Examine plunger (36) and seals (40,42,43B).

When replacing plunger (36), tighten new plunger to 26 ft.lbs.

Replace worn parts; grease seals with Silicone before installing.

**CAUTION:** Don't loosen the 3 plunger (36) before the valve casing has been removed otherwise the plunger (36) could hit against the spacer pipe (51F) when the pump is being turned. Seal life can be increased if the pretensioning allows for a little leakage. This assists lubrication and keeps the seals cool. It is therefore not necessary to replace seals before the leakage becomes too heavy and causes output and operating pressure to drop.

---

## GP7124A REPAIR INSTRUCTIONS

---

### MOUNTING VALVE CASING

Check O-rings (39A) and support rings (39B) on seal case (39). Clean surfaces of seal sleeves in gear box and sealing surfaces of valve casing.

Push valve casing carefully onto O-rings of seal case and centering studs (50A). Tighten nuts (49A) to 103 ft-lbs.

### TO DISASSEMBLE GEAR

Take out plunger and seal sleeves as described above. Drain oil. After removing the circlip ring (33B), lever out seal retainer (33) with a screw driver. Check seals (32,32A,33A) and surfaces of crosshead. Remove crankcase cover (4). Loosen inner hexagon screws on the connecting rods (24) and push con rod halves as far into the crosshead guide as possible.

**CAUTION:** Connecting rods are marked for identification. Do not twist con rod halves. Con Rod is to be reinstalled in the same position on shaft journals.

Check surfaces of connecting rod and crankshaft (22)

Take out bearing cover to one side and push out crankshaft taking particular care that the con rod doesn't get bent.

**CAUTION:** Seal (32A) must always be installed so that the seal-lip on the inside diameter faces the oil. Reassemble in reverse order: Regulate axial bearing clearance - minimum 0.1mm, maximum 0.15mm-by means of fitting disc (20A). Shaft should turn easily with little clearance. Tighten inner hexagon screws to 30 ft.-lbs.

**CAUTION:** Connecting rod has to be able to be slightly moved sidewise at the stroke journals.

## GP7124A TORQUE SPECIFICATIONS

<u>Position</u>	<u>Item#</u>	<u>Description</u>	<u>Torque Amount</u>
10	13133	Hexagon Screw	30 (ft.-lbs)
36	13138	Plunger	26 (ft.-lbs.)
49A	13160	Nut	103 (ft.-lbs)

## GP7124A Dimensions (Inches)

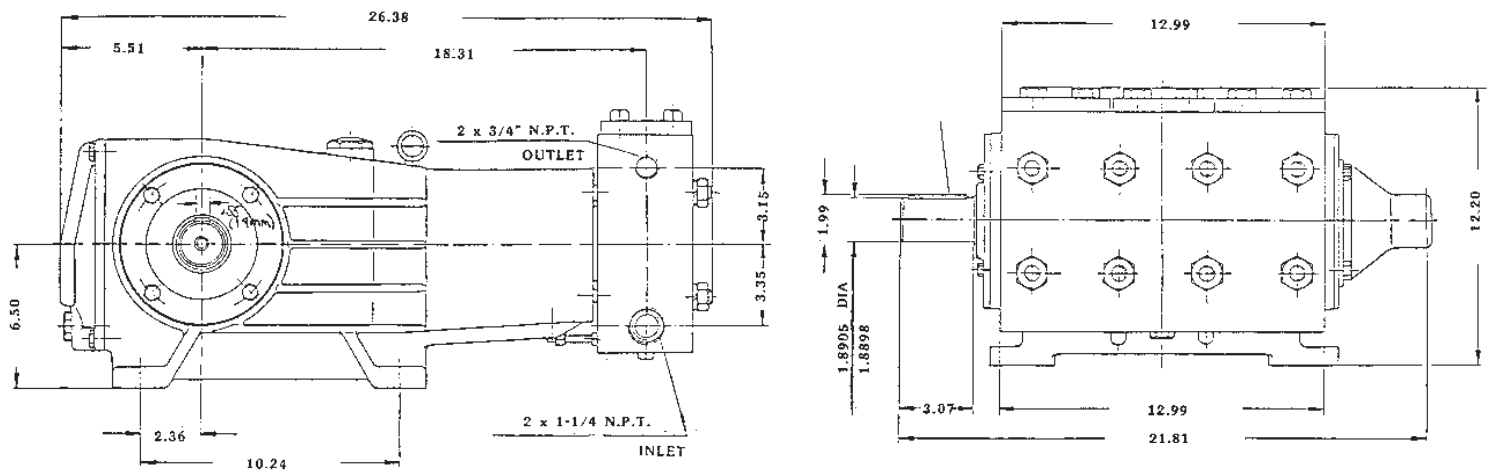

### GIANT INDUSTRIES LIMITED WARRANTY

Giant Industries, Inc. pumps and accessories are warranted by the manufacturer to be free from defects in workmanship and material as follows:

1. For portable pressure washers and car wash applications, the discharge manifolds will never fail, period. If they ever fail, we will replace them free of charge. Our other pump parts, used in portable pressure washers and in car wash applications, are warranted for five years from the date of shipment for all pumps used in NON-SALINE, clean water applications.
2. One (1) year from the date of shipment for all other Giant industrial and consumer pumps.
3. Six (6) months from the date of shipment for all rebuilt pumps.
4. Ninety (90) days from the date of shipment for all Giant accessories.

This warranty is limited to repair or replacement of pumps and accessories of which the manufacturer's evaluation shows were defective at the time of shipment by the manufacturer. The following items are NOT covered or will void the warranty:

1. Defects caused by negligence or fault of the buyer or third party.
2. Normal wear and tear to standard wear parts.
3. Use of repair parts other than those manufactured or authorized by Giant.
4. Improper use of the product as a component part.
5. Changes or modifications made by the customer or third party.
6. The operation of pumps and or accessories exceeding the specifications set forth in the Operations Manuals provided by Giant Industries, Inc.

Liability under this warranty is on all non-wear parts and limited to the replacement or repair of those products returned freight prepaid to Giant Industries which are deemed to be defective due to workmanship or failure of material. A Returned Goods Authorization (R.G.A.) number and completed warranty evaluation form is required prior to the return to Giant Industries of all products under warranty consideration. Call (419)-531-4600 or fax (419)-531-6836 to obtain an R.G.A. number.

Repair or replacement of defective products as provided is the sole and exclusive remedy provided hereunder and the MANUFACTURER SHALL NOT BE LIABLE FOR FURTHER LOSS, DAMAGES, OR EXPENSES, INCLUDING INCIDENTAL AND CONSEQUENTIAL DAMAGES DIRECTLY OR INDIRECTLY ARISING FROM THE SALE OR USE OF THIS PRODUCT.

THE LIMITED WARRANTY SET FORTH HEREIN IS IN LIEU OF ALL OTHER WARRANTIES OR REPRESENTATION, EXPRESS OR IMPLIED, INCLUDING WITHOUT LIMITATION ANY WARRANTIES OR MERCHANTABILITY OR FITNESS FOR A PARTICULAR PURPOSE AND ALL SUCH WARRANTIES ARE HEREBY DISCLAIMED AND EXCLUDED BY THE MANUFACTURER.

